

(No Model.)

4 Sheets—Sheet 1.

V. F. CARPENTER.
WRENCH MILLING MACHINE.

No. 489,523.

Patented Jan. 10, 1893.

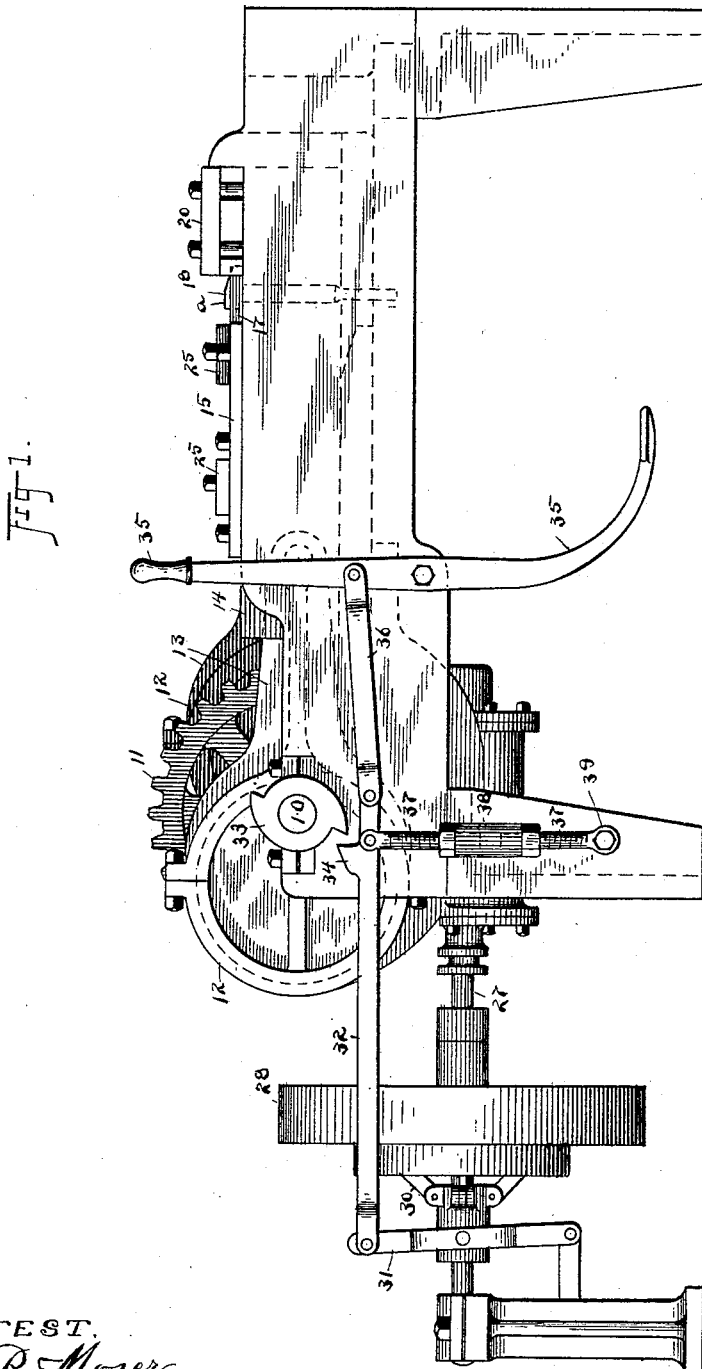

ATTEST.
R. B. Moser.
A. J. Symes.

INVENTOR.
Vernum F. Carpenter.
by
H. T. Fisher.
ATTORNEY.

V. F. CARPENTER.
WRENCH MILLING MACHINE.

No. 489,523.

Patented Jan. 10, 1893.

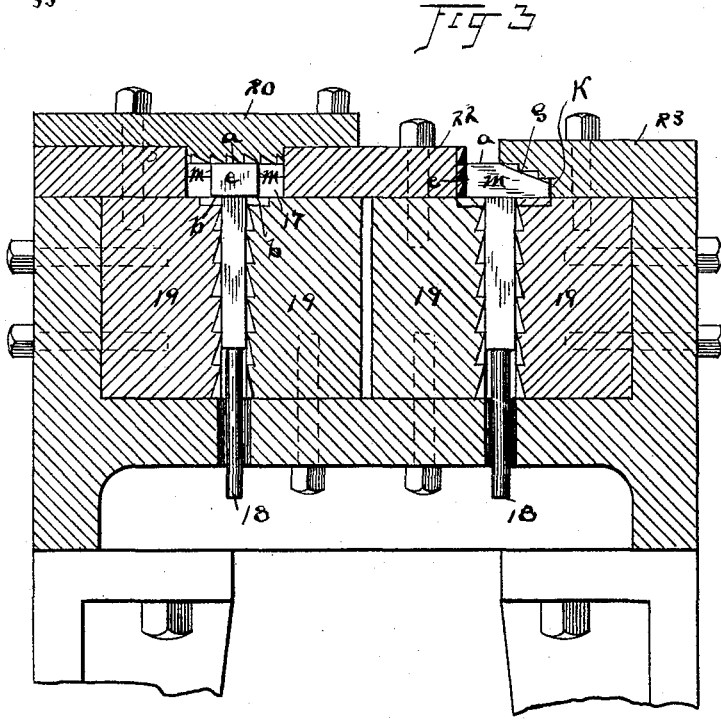
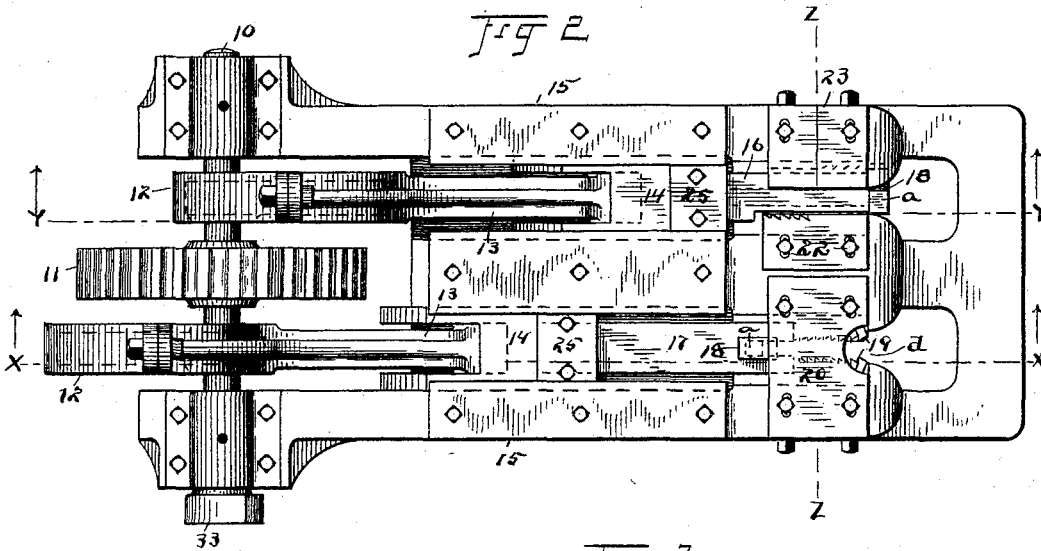

ATTEST.
R. B. Moser.
A. J. Symes

INVENTOR.
Vernum F. Carpenter.
 by
H. F. Fisher.
 ATTORNEY.

V. F. CARPENTER.
WRENCH MILLING MACHINE.

No. 489,523.

Patented Jan. 10, 1893.

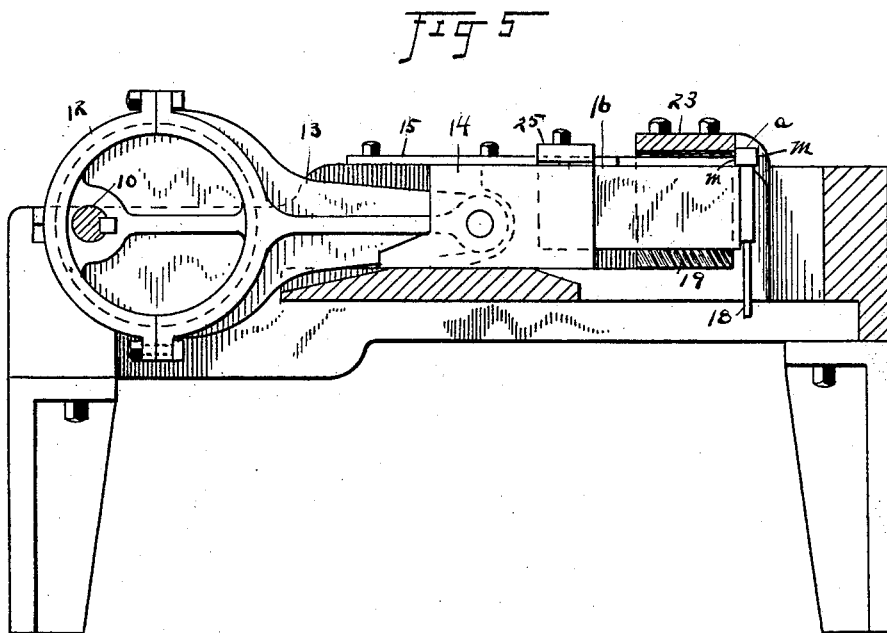
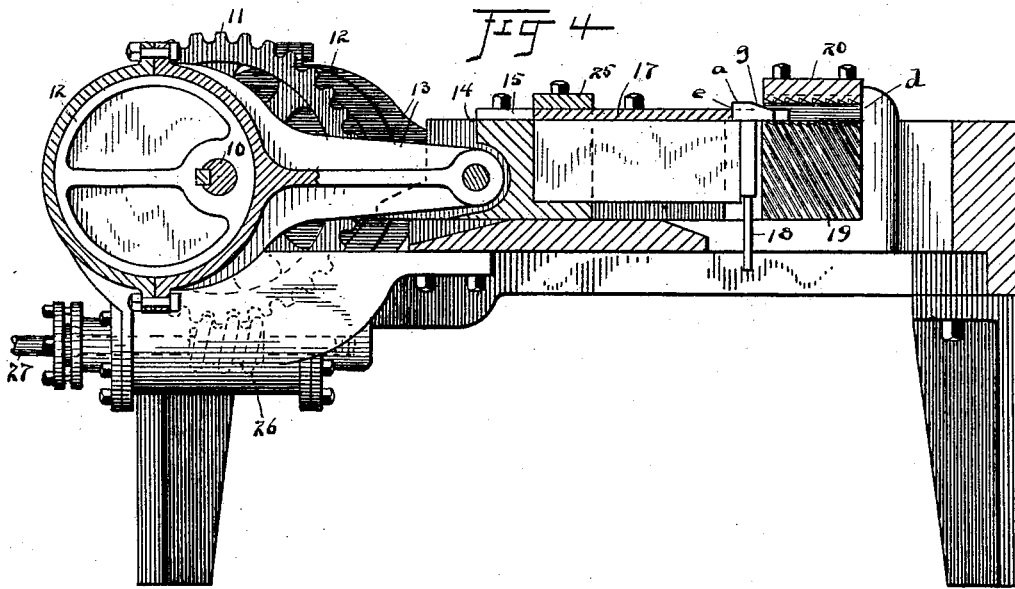

ATTEST
R. B. Moser.
A. J. Symes Jr.

INVENTOR.
Vernum F. Carpenter.
 by
H. F. Fisher
 ATTORNEY.

(No Model.)

4 Sheets—Sheet 4.

V. F. CARPENTER.
WRENCH MILLING MACHINE.

No. 489,523.

Patented Jan. 10, 1893.

Fig 6

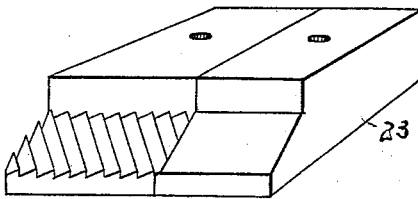
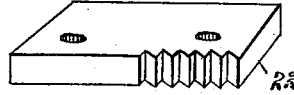

Fig 7

Fig 8

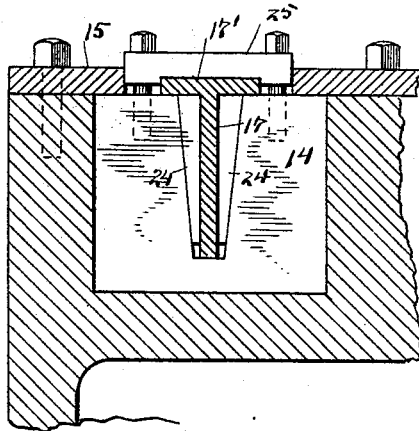
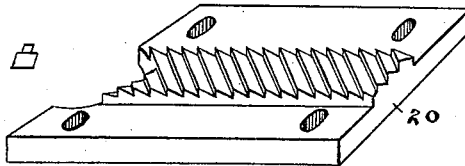

Fig 9

ATTEST.
R. B. Moser,
A. J. Symcox

by
A. F. Fisher

INVENTOR.
Vernum F. Carpenter.

ATTORNEY.

UNITED STATES PATENT OFFICE.

VARNUM F. CARPENTER, OF CLEVELAND, OHIO.

WRENCH-MILLING MACHINE.

SPECIFICATION forming part of Letters Patent No. 489,523, dated January 10, 1893.

Application filed April 4, 1892. Serial No. 427,593. (No model.)

To all whom it may concern:

Be it known that I, VARNUM F. CARPENTER, a citizen of the United States, residing at Cleveland, in the county of Cuyahoga and State of Ohio, have invented certain new and useful Improvements in Wrench-Milling Machines; and I do hereby declare that the following is a full, clear, and exact description of the invention, which will enable others skilled in the art to which it appertains to make and use the same.

My invention relates to wrench milling machines, and the invention consists in a machine in which the smooth surfaces of a wrench are milled, substantially as shown and described, and particularly pointed out in the claims.

In the accompanying drawings, Figure 1 is a side elevation of my improved milling machine. Fig. 2 is a plan view of the machine, with the clutch and drive mechanism shown at the rear of Fig. 1 omitted. Fig. 3 is a cross section of the machine taken on line *z, z*, Fig. 2. Fig. 4 is a longitudinal section of the machine, taken on line *x, x*, Fig. 2, and showing a wrench-blank in position to be moved forward by the plunger. Fig. 5 is a longitudinal section on line *y, y*, Fig. 2, showing the plunger at the forward extremity of its stroke as it appears after the wrench blank has been forced through the mill on that side of the machine. Fig. 6 is a perspective detail view of the milling plate which mills the head of the hammer on its hammering surface. Fig. 7 is a perspective detail view of the milling plate or block which mills the back beveled surface of the head, as clearly seen in section in Fig. 3. Fig. 8 is a detail perspective view of the plate which mills the outer flat portion of the head where the bevel terminates. Fig. 9 is a transverse section of a portion of the machine, including the plunger, and is designed to show the construction of the plunger in cross section.

The machine, as appears in the drawings, has a double set of plungers and a double set of eccentrics, each set being substantially a duplicate of the other, and designed for a like purpose, the purpose of the dual set of plungers being to mill the four sides of the wrench in the machine, by simply changing the wrench from one side to the other and exposing its opposite sides to action of the cut-

ters. Thus in passing the wrench through the first set of cutters, two of its sides and certain portions of the head are milled; then the blank is transferred by hand into the other side of the machine, and the second plunger, operating like the first one, forces the blank through the mill mechanism of that side, thus completing the milling of the wrench on all sides, as will appear farther on.

Referring now to the mechanism by detail, whereby the functions of the machine are worked out, we have, first, a main shaft 10, operated by a gear 11, or equivalent connection. Upon this shaft are two eccentrics, 12, of any common and well-known construction, familiar in steam engines and other heavy machinery, and built of such strength and such stroke, in this instance, as to do the work required of them. Each eccentric is connected by a pitman 13, with a slide head 14, supported in a suitable frame 15, and connected to these heads, which are similar in construction and operation, are the two plungers 16 and 17. These plungers are substantially T shape in cross section, and the vertical portion of the plungers corresponds in width and depth to the length and thickness of the body of the wrench 18, so that when the plungers are bearing against the said body, it has a wide bearing surface and holds the wrench uniformly across its width, thereby carrying it evenly forward and making the milling cutters equally effective at all points. Any suitable guideway for the plungers may be adopted. It will be observed that the eccentrics 12, are set oppositely upon the shaft 10, so that when one plunger is carried forward to the extent of its stroke, the other plunger will be carried back to the rear limit of its stroke. This enables the operator to lift the wrench or wrench-blank from the first milling mechanism or set of cutters and place it in position to pass through the second set of cutters, with the plunger of the lathe mill out of the way.

Part of the cutting mechanism of each set of mills is the same. Thus, each set of mills has two side plates, 19, arranged with their faces opposite one another, and having their cutting corrugated edges running diagonally across their face, as shown in Fig. 4. The relation of these side mill plates or blocks 19 to

one another, is clearly apparent in Fig. 3, and they may be more or less adjustable, if desired, so as to work more or less closely to one another, according to the size and character of the body of the wrench which they are intended to mill. In front of these plates or blocks, and between them and the plunger in its back stroke, is an opening into which the stem or body of the wrench may be inserted, and in which it is supported by its head overhanging and resting upon the adjacent walls. When the wrench is placed in this position, it is in position to be milled, and assuming that it be placed in the first set of mills, shown in longitudinal section in Fig. 4, and in cross section in Fig. 3, we have in addition to the side milling walls, blocks or plates 19, the milling plate 20, shown in Fig. 8, as also in Figs. 2, 3, and 4, and adapted to mill the flat outer portion, *a*, of the head of the wrench, Fig. 4. In addition to the side of the body and the flat portion *a* being milled in this first operation, it will be observed that the side mills 19 have cutting edges along their top to mill the lateral extending portions of the head on its inner side and at the side of the body; hence, in passing through this first mill, two sides of the body, the flat surface, *a*, and the lateral projecting under surfaces at the sides of the head, indicated by *b*, Fig. 3, at the left, also are milled. This being the arrangement of milling surface for the first set of mills, and the plunger being forced forward by its eccentric, the wrench blank is carried through to the point indicated by *d*, Fig. 2.

It will be seen that the top plate 20 is cut out slightly along its front edge to make it convenient for the hand to grasp the head of the wrench as the plunger 17 reaches the end of this stroke, so that the said wrench may be seized and transferred to the second set of mills as herein described.

The operation of the mechanism in the second set of mills is a repetition of that in the first set, but in this case the other two sides of the body 18 of the wrench are milled by means of side milling plates, blocks, or other equivalent means, 19, the same as shown in Fig. 4. This difference, however, occurs in these blocks 19, namely; that they have a wider surface of the head of the wrench to mill than is exposed in the first operation, and hence the upper milling edge of said blocks is widened to meet this additional demand for milling surface. Otherwise the said blocks or cutters are similar to those shown in the first set of mills. In this second operation I have the milling plate 22, shown in detail, in Fig. 6, and in cross section in Fig. 3, and provided with milling teeth or cutters to engage the hammer portion, *e*, of the head of the wrench, and the plate 23, likewise shown in section in Fig. 3, and in detail in Fig. 7, with milling teeth to mill the beveled portion *g* of the wrench. In this case the plunger operates precisely as it does in the other set of

mills, and when the wrench blank has been placed in position, and the machinery started, the blank is forced forward by the plunger and the surfaces hereinbefore referred to are milled. As a result of this double and practically continuous operation in the same machine, the body of the wrench is perfectly milled on its four sides, and every portion of the head is milled excepting the two opposite sides *m*, thereof, which cannot be reached in this machine because of the room required for the plunger. The toe of the head, *k*, likewise is left without milling.

The plungers 16 and 17 are each held in the head 14 by means of wedges 24, and a recess is formed in the front of the head 14 into which the rear end of the plunger projects and in which the said wedges are seated. The wedges come beneath the top flanges of the plunger, and plunger and wedges are driven to their place together. A cross plate, 25, screwed onto the head 14, secures said parts or pieces down in position. At its front the cross flange 17' of the plunger bears against the head of the wrench in driving it through the mill.

Power is applied to the shaft 10 through worm gear 26, Fig. 4, on power shaft 27, having, in this instance, a band wheel 28. A sleeve clutch 30, sliding on shaft 27, serves to engage said band wheel with shaft 27, and the clutch is controlled through a lever 31 and a bar or rod 32. Automatic control of this clutch and lever is effected through cams 33 on shaft 10, bearing against projection 34 on bar 32, and at will by the operator through combined hand and foot lever 35, connected to the end of bar or rod 32 by link 36. If the automatic stop be employed, the machine will be stopped every half revolution of shaft 10, carrying eccentrics 12, so that every time the plungers reach the forward limit of their stroke a stop of the machine will occur. This enables the necessary changes of the wrench to be made. By means of hand and foot lever 35 the machine can be stopped at any time. If the automatic operation be not desired, the bar 32 can be adjusted away from cams 33 by screw and nut mechanism 37 and 38, Fig. 1. Said parts are pivoted at 39 to allow back and forth movement.

Any suitable frame to support the mechanism herein described may be adopted.

Having thus described my invention, what I claim as new and desire to secure by Letters Patent, is:

1. In a wrench milling machine, oppositely arranged milling blocks or cutters arranged to mill the body of the wrench beneath the head, and the under side of the head, in combination with means to press the head down on the said under side cutters, and a suitable plunger to carry the wrench forward, substantially as described.

2. In a wrench milling machine, milling cutters for the under side of the head, in combination with rigidly affixed milling cutters

for the top or opposite side of the head, and a plunger, substantially as described.

3. In a wrench milling machine, a set of cutters to mill the body of the machine below the head, in combination with a cutter for the top or outer portion of the head, and a plunger, substantially as described.

4. In a wrench milling machine, the combination of the cutters, 19, having milling surfaces at right angles to each other to mill the under side of the head of the wrench and the body thereof respectively, in combination with a detachable top milling plate, and a

plunger arranged to pass beneath said top plate, substantially as described.

5. The sliding head having a recess in one end, the plunger having lateral flanges at the top, and wedges for securing the plunger in said head, substantially as described.

Witness my hand to the foregoing specification.

VARNUM F. CARPENTER.

Witnesses:

H. T. FISHER,
NELLIE L. McLANE.